

# CON-E-CO®

An Oshkosh Truck Corporation Company



# HRM-12

---

HORIZONTAL REVERSING MIXER

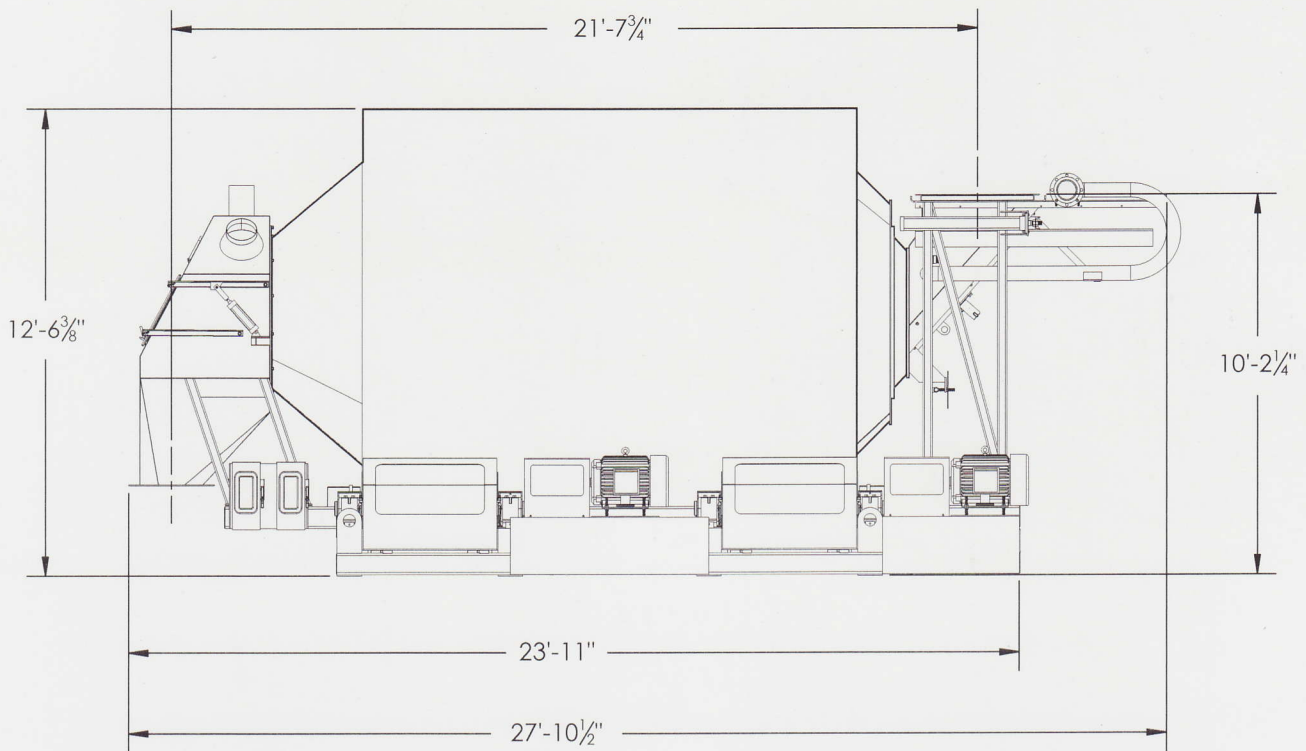

## HRM Model 12 Horizontal Reversing Mixer

### SPECIFICATIONS:

#### CAPACITY

- 12 cubic yards

#### MIXER DRUM

- 38" diameter inlet
- 46" diameter outlet
- 3/4" steel drum shell
- 3/8" steel inlet and outlet cones
- 1" polyurethane blade liners on drum and cones

#### MIXING PADDLES

- Six bolt-in A36 steel drum mixing paddles
- 1" polyurethane furnished on mixing side of drum shell paddles
- A.R. 400 1/4" steel wear plate on discharge side of drum shell paddles
- Three bolt-in dual element 1/2" steel paddles
- A.R. 400 1/4" steel wear plate on dual element paddles
- Bolt-in dual element spider paddles support
- Three bolt-in A36 steel discharge paddles
- A.R. 400 1/4" steel wear plate on discharge paddles

#### DRIVES

- Four 50 H.P. T.E.F.C. motors
- Enclosed gear reducers
- High capacity friction drive
- Retractable 230-volt, single-phase emergency drives

#### ELECTRICAL SYSTEM

- 460 volt
- Variable-frequency reversing drive control
- Climate-controlled panel enclosure
- Circuit breaker main disconnect
- NEMA 12 enclosures
- U.L. Listed panels
- Knife switch furnished for each motor

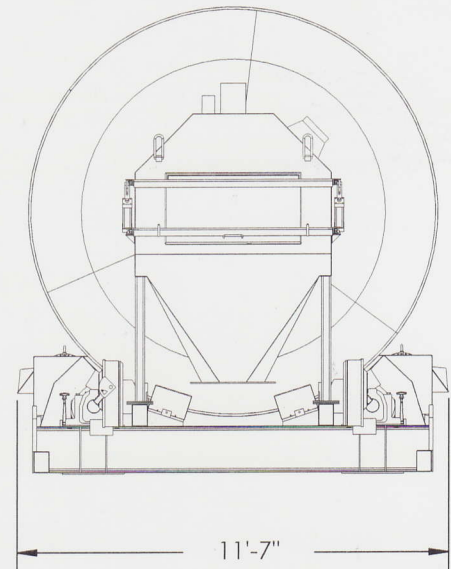

#### INLET CHARGING HOPPER

- Powered 36" travel retractable assembly
- 6" water manifold with dual 4" outlets
- One-piece urethane charging seal
- Ceramic-tiled 1" urethane hopper liners
- 10" diameter cement tube

#### DISCHARGE HOPPER/DUST CONTROL SHROUD

- Transit mixer charging shroud
- 1" urethane liner at impact area
- Provision for camera view port and light
- Dust control suction inlet ring

**NOTE:** In accordance with CON-E-CO's policy of constantly improving its products, these specifications are subject to change without notice.

Proud  
Member of



# CON-E-CO®

An Oshkosh Truck Corporation Company

Address: P.O. Box 430  
Blair, NE 68008

Phone: (402) 426-4181

Fax: (402) 426-4180

Website: [www.con-e-co.com](http://www.con-e-co.com)

E-Mail: [sales@con-e-co.com](mailto:sales@con-e-co.com)